

Bearing test rig EELPAX-130

Specification

(Dipl.-Ing. Hagen Elgeti, MBA)

ELGETI ENGINEERING GMBH
Geschäftsführer: Hagen Elgeti
Liebigstraße 15
52070 Aachen

Tel.: +49 (0) 241 16 91 93 0
Fax: +49 (0) 241 16 91 93 10
he@elgeti-engineering.de
www.elgeti-engineering.de

Bankverbindung:en
Aachener Bank eG
Kto-Nr.: 0145 147 018
BLZ: 390 601 80
IBAN: DE46390601800145147018
BIC: GENODED1AAC

Sparkasse Aachen
Kto.Nr.: 1070 510 985
BLZ: 390 500 00
IBAN: DE07390500001070510985
BIC: AACSDE33

Handelsregister: HRB 15799
Amtsgericht Aachen
Ust-IdNr.: DE268539542

Content

CONTENT.....	2
1 TABULAR OVERVIEW.....	3
2 PURPOSE.....	4
3 FUNCTION	5

1 Tabular overview

Purpose	Testing of lubricants referring to DIN 51819 Lifetime tests on axial bearings (outer diameter from 85 mm to 130 mm)
Number of test stations	2
Number of test bearings	2
Load direction	Axial
Max. load	110 kN
Max speed	6 000 rpm (max. 5 500 W per station; optional with larger drives)
Lubrication	Oil circuit with tank, filter and air cooler. Optional: electric heating. (Grease and oil sump lubrication are possible as well.)
Sensors	Outer ring temperature, oil supply and oil drain temperature, vibration sensor, and motor current. Optional: particle counting system, friction torque
Outer dimensions	1 800 mm x 1 400 mm x 1500 mm (L x W x H)

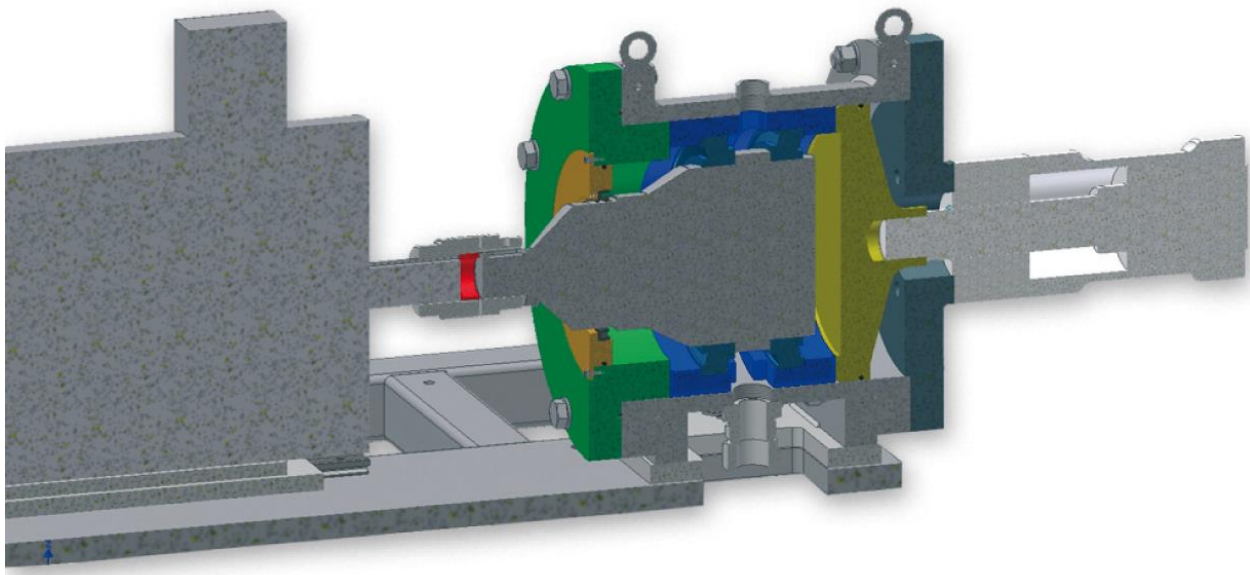

Figure 1: Sketch of test unit



Figure 2: EELPAX-130 (left station equipped with heating; control PC at separate position)

2 Purpose

The EELPAX-130 is a bearing test rig allowing lubrication tests using exactly the parameters specified in DIN 51819. The purpose of these tests is assessment of the wear protection properties of both greases and oils in driven bearings in wear critical conditions. DIN 51819 prescribes the FE8 type test rig. However, from a tribological point of view, the EELPAX-130 fulfils the requirements of the standard.

The test rig is also suitable for a broad spectrum of lifetime tests on bearings with outer diameters in the range from 85 mm to 130 mm. The EELPAX-130 can be used for the following bearing types:

- Angular contact ball bearings
- Four point contact bearings
- Tapered roller bearings

- Spherical roller bearings
- Axial deep groove ball bearings
- Axial angular contact ball bearings
- Axial cylindrical roller bearings
- Axial needle roller bearings
- Axial spherical roller bearings
- Crossed roller bearings

The test parameters are defined by rotational speed, axial load and temperature, which are controlled parameters with limits 6 000 rpm, 110 kN and 100°C respectively. Where friction power is insufficient to reach the desired temperature, optional electric heating can be applied. Precise control of the test parameters ensures maximum precision and repeatability of test results. Complex load cycles or load steps may be programmed, including conditional steps. For example, should a bearing survive the prescribed test duration, a conditional step may be triggered to increase the load to cause bearing failure to provide data for subsequent damage accumulation calculations.

3 Function

The test rig consists of a coated steel frame, a control box, a control PC and two test stations (Figure 2). The PC can either be co-located with the machine or positioned remotely.

The parts of each test station comprise a base plate, a speed controlled electric drive system (frequency converter, asynchronous motor with forced ventilation), a hydraulic system (tank, pump, pipes, valves, cylinder etc.) and the test head in which the shaft with two test bearings (plus two support bearings, if pure axial bearings are tested) is situated. This is loaded axially by the cylinder and driven by the motor. A circulating lubrication system (oil pump, pipes, air cooler and optional controlled electric test head heating) may form part of the test head. The shaft and the outer ring seats have to be individually adapted and manufactured for each bearing size.

Both test heads are independent from each other, allowing them to be driven with different test parameters, and different lubricants; one test station may be assembled/disassembled while the other is in operation.

Sensor signals are logged to PC at 1 Hz and recorded in a *.txt file for post processing. The operator can define limits for all measured values for automatic shut-down in the event of bearing failure.